



LHP feeder, plus booklet module with own servo drive

Configuration

- Servo friction feeder LHP
- Flighted belt conveyoyr

Application:

- Feeding and accurate positioning of printed and folded booklets

Performance data:

- Performance: max. 500 booklets/min. (depending on product)
- Format range:
 - width: 60 – 200 mm,
 - length: 30 – 250 mm
- Positioning accuracy: +/- 1 mm

Functionality:

The pre-fabricated booklets have to be put into the stacking magazine, in order to be separated by the friction feeder and then they are fed onto the flighted belt conveyor.

The booklets are exactly aligned on the flighted belt conveyor and transferred via knife edge with the label carrier material into the labelling machine. Simultaneously, the booklets on the carrier material are covered with the lamination film from top.

The high positioning accuracy of approx. +/- 1 mm is achieved through the exact synchronisation of feeder and flighted belt conveyor by means of an encoder.

The booklet module is characterised by its compact design and short changeover time. Up to 30,000 labels per hour can be produced. The module is delivered as standard module for all labelling machines.



Booklet open and laminated

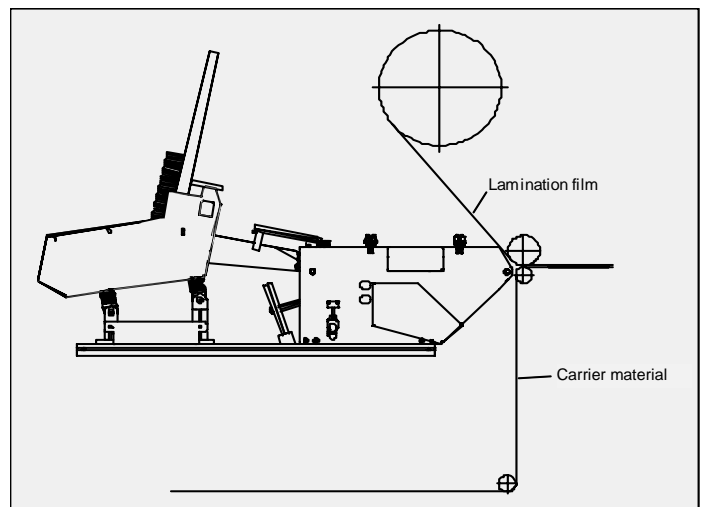

Layout booklet module